

[1700K-6]

The 1700K-6 is our most economical 6" K-Style gutter machine. It features a high performance electric motor, tape holder, double uprights, rack shear and a single gutter spool. With the K-6, you get the "seamless advantage", along with less material, less labor and less maintenance.

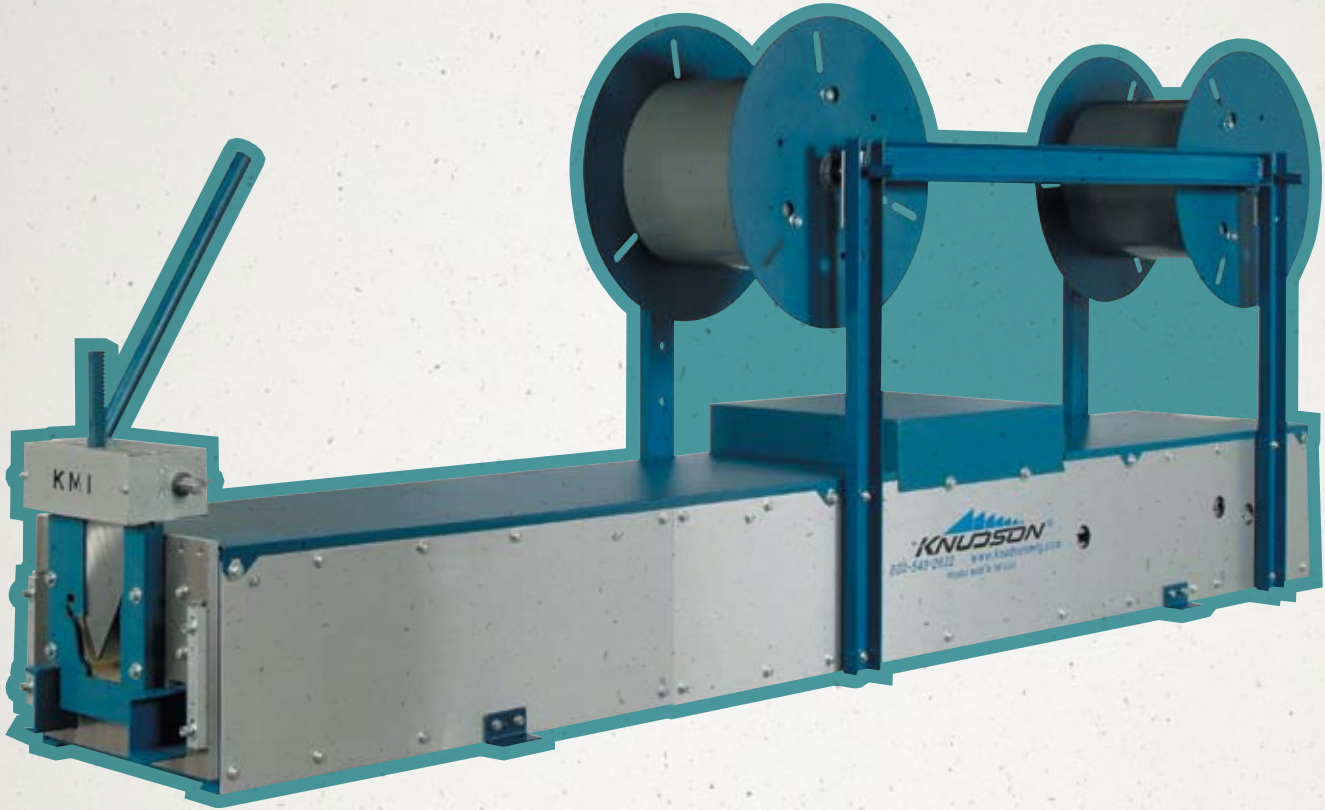

[1700K-6 Profile Dimensions]

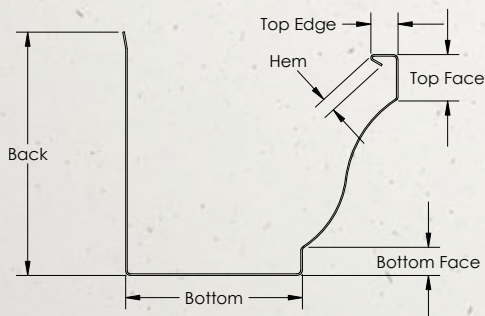

Back	5.00"
Bottom	3.88"
Bottom Face	0.50"
Top Face	0.88"
Top Edge	0.75"
Hem	0.38"

Profile Specifications

Available 6" K-Style Rain Gutter Profiles:

- 6" K-Style Gutter with Straight Back

Profile Dimensions:

- Refer to Knudson Engineering Data or Knudson Profile Drawing for Specifications

Material Types:

- Steel Galvanized, Painted, Pre-Finished, Bare
- Aluminum Painted, Pre-Finished
- Copper Bare

Material Thickness:

- Steel 0.015" to 0.018" (.38 to .45-mm)
- Aluminum 0.023" to 0.032" (.57 to .81-mm)
- Copper 16 to 20-oz (.53 to .69-mm)

Material Strength:

- Steel Max Tensile Strength = 48-ksi (330 Mpa)
Max Yield Strength = 33-ksi (230 Mpa)
- Aluminum Max Tensile Strength = 33-ksi (230 Mpa)
Max Yield Strength = 28-ksi (190 Mpa)
- Copper Max Tensile Strength = 33-ksi (230 Mpa)
Max Yield Strength = 28-ksi (190 Mpa)

Strip Width:

- Minimum 14.75" (230-mm)
- Maximum 15.06" (382-mm)

Machine Specifications - Mechanical Systems

Dimensions:

- Length 136.00" (3450-mm)
- Width 24.00" (610-mm)
- Height 21.00" (530-mm)
- Height 41.00" (1040-mm) including uprights
- Height 50.00" (1270-mm) including spool
- Weight 1375-lbs (625-kg)

Roll-Forming Details:

- Eight (8) Powered Roll-Forming Stations
- Four (4) Station Auxiliary Box-Forming Unit

Production Speed:

- 35'/min Nominal (60 Hz Electric Motor @1725 rpm)
- 29'/min Nominal (50 Hz Electric Motor @1425 rpm)

Drive Train:

- Power Source: Electric Motor
- Power Take-Off: Worm Gear Reducer
- Drive/Forming Rollers: Gear/Sprocket/Roller Chain Drive
- Main Drive Speed: 54 rpm @ 2.50" Drive Dia (60 Hz Electric Motor @1725 rpm)
- Main Drive Speed: 44 rpm @ 2.50" Drive Dia (50 Hz Electric Motor @1425 rpm)

Shear Assembly:

- Manually Operated Guillotine Style
- Manually Operated Rack and Pinion Style

Coil Handling Equipment:

- Spool: 12" Wide/16" ID
- Double Uprights
- Multi-Width Coil Cradle
- Triple Uprights

Airborne Noise Emissions:

- Equivalent continuous A-weighted sound pressure level = less than 70 dB (A)

Machine Specifications - Electrical Systems

Electric Power:

- Line Voltage = 100 to 115 VAC / 200 to 230 VAC (+/- 10%)
- Line Current = 15 Amps
- Line Frequency = 60 / 50 Hz (+/- 1%)
- Line Phase = single phase
- Full Load Current = 12.6 to 14.2 Amps (115 VAC) / 6.3 to 7.1 Amps (230 VAC)
- Fuse Rating = N/A
- Electrical Drawing = 31-0020110 (115 VAC) / 31-0020104 (230 VAC)
- Electrical Drawing = 31-0020109 (115 VAC) / 31-0020105 (230 VAC) (Safety Wiring)
- Electrical Enclosure IP Rating = N/A

Control System:

- Directional Control / Electric Motor Control: Three (3) Position Drum Switch

Safety Features:

- E-Stop Switch
- Top and Side Covers
- Spool Locks

Machine Specifications - Operating Environment

Ambient Air Temperature:

- +41 to +131-deg Fahrenheit (+5 to +55-deg Celsius)
- Up to 24 hours at 122-deg Fahrenheit (50-deg Celsius)

Humidity Range:

- No Restrictions

Altitude Range:

- No Restrictions

Vibration Shock and Bump:

- Minimal vehicular transport on maintained roads
- Off-road transportation not recommended

Transportation and Storage:

- -13 to +131-deg Fahrenheit (-25 to +55-deg Celsius)
- Up to 24 hours at +158-deg Fahrenheit (+70-deg Celsius)

Explosive Atmosphere:

- Should not be operated in any kind of explosive atmosphere